

RAVE! RADIO MIXING CONSOLE USER MANUAL

© 2026 ANGRY AUDIO LLC



RAVE! Radio mixing console.



Power supply (shown with optional rack mount kit).

Contents

A Note from the Founder	2
Safety & Compliance	3
Installation & Configuration	4
Unpacking	4
Installation	4
Audio Wiring	4
Control Wiring	5
Cable Management	6
Connections	7
Mic/Line Inputs (Channels 01-04)	7
Microphone Calibration	8
Line Inputs (Channels 05-08)	8
External Line Input	9
Program & Audition Outputs	9
Mix-Minus Outputs	10
Monitor Outputs	11
Logic Connections	12
Logic Examples	14
Operation	15
Microphone Fader Channels	15
Line Fader Channels	16
Mix-Minus Outputs and User Buttons	17
Monitors (Board Operator)	18
Headphones (Board Operator)	19
Studio Guests	20
Meters	21
Specifications	22
Warranty & Support	24

A Note from the Founder

Thank you for choosing the RAVE! radio mixing console. I've designed a lot of radio consoles in my career, PR&E, Axia, Lawo. I'm proud of all of them. It's astonishing to see consoles I designed nearly 40 years ago still on the air. Wow.

RAVE! was a different challenge. I set the price before ever putting pencil to paper, then set out to design a low-cost console that would still make me proud.

Did you know that all Angry Audio products are backed by a 30-day "love it or return it" guarantee? This is an industry first. Yes, this promise extends even to our consoles. If you don't absolutely love it, you can send it back— no restocking fees, no lengthy forms, no hassles.

I would love to hear from you! If you have questions or comments, drop me a note using the form on our website:

<https://angryaudio.com/contact>

I promise to answer quickly. Thank you for your trust and business. I am truly grateful!

Michael Dosch (aka Catfish)

Safety Guidelines

Safety Guidelines

We know you're itching to dive in. But slow down and read this section first. Your safety matters to us — partly because we like you, partly because lawyers.

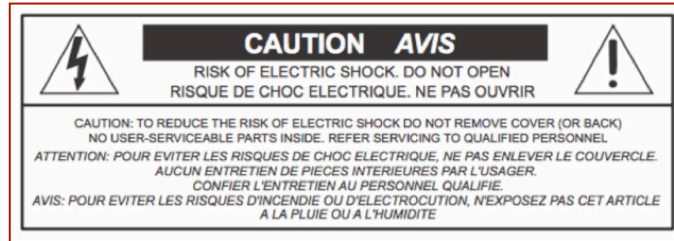

- ⚠ This product contains potentially-lethal voltages. Do not open unless you are qualified to do so.
- ⚠ Do not use this product if it has been dropped, damaged or exposed to water.
- ⚠ Do not expose to rain or moisture.
- ⚠ Do not use near flammable materials such as aerosols or oxygen.
- ⚠ Do not insert objects into product openings. We're looking at you there with the greenie.
- ⚠ Do not use in applications in which a life-threatening injury could result due to failure.
- ⚠ Use caution with audio levels. Exposure to excessive volume can permanently damage hearing.
- ⚠ Be careful. 90% of all people are caused by accidents.

Compliance Declarations

In the U.S., this product complies with the limits for a Class A computer device as specified by FCC Rules, Part 15, Subpart J, which are designed to provide reasonable protection against such interference when this type of equipment is operated in a commercial environment.

In Canada, this product does not exceed the Class A limits for radio noise emissions set out in the Radio Interference Regulations of the Canadian Department of Communications.

In Europe, this product complies with the requirements of the EEC Council Directives 93/68/EEC (CE Marking), 73/23/EEC (safety – low voltage directive), and 89/336/EEC (electromagnetic compatibility). Conformity is declared to standards EN50081-1 and EN50082-1.

This product uses RoHS compliant materials. At the end of its useful life, this product is to be recycled by an authorized waste electrical and electronic equipment recycler. Alternatively, the product may be returned to Angry Audio LLC for recycling. Contact us at answers@angryaudio.com for instructions.

Unpacking RAVE!

Inspect your shipment to ensure you received everything. Each RAVE! Console consists of the following items:

- RAVE! radio mixing console.
- Console power supply.
- AC power cord (connects power supply to AC mains).
- DC cable (connects console to power supply).

Contact your reseller immediately if anything is missing or damaged. You may want to save the packing materials for later use. Or you may want to use them to create a cool kitty condo. We won't tell.

Installation

Find a suitable location for your power supply. Ensure adequate ventilation around the supply. If you have space available in an equipment rack, you will want to order the optional Angry Audio rack mount kit (P/N 992001) from your favorite reseller. It makes for a very clean and professional installation.

Place the console on your tabletop. Do not energize the power supply yet. Hook up the DC power cable between the power supply DC OUTPUTS connector and the console DC INPUTS connector. Both ends of the DC power cable are identical. Make sure the connectors are fully inserted and locked on both ends.

Now you may energize the power supply. Connect the AC power cord into the power supply first. Then plug the other end into a Mains receptacle. Do **not** defeat the safety ground prong on the power cord. Use clean AC power. Sharing a receptacle with a mini-split, for example, may create noise in your audio.

As a professional broadcast console, RAVE! is designed for 24/7 operation. If you wish to de-energize the console, remove the AC power cord from the Mains receptacle. **Never connect or disconnect the DC power cable while the power supply is energized.**

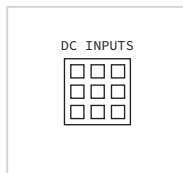

CONNECTOR	PIN	SIGNAL
DC Inputs	1	-15VDC Audio Supply
DC Inputs	2	Audio Common
DC Inputs	3	+15VDC Audio Supply
DC Inputs	4	+48 VDC Phantom Supply
DC Inputs	5	Audio Common
DC Inputs	6	No Connection
DC Inputs	7	+12VDC Logic Supply
DC Inputs	8	Logic Common
DC Inputs	9	Chassis Ground

DC Connector and Pinout. Same on console and PSU.

Audio Wiring

All of the line inputs and outputs are on RJ45 connectors using the StudioHub+ pinout. StudioHub uses shielded CAT-5 cables to transport analog and digital audio. Adapters are available to interface to a wide variety of common audio connector types.



StudioHub to XLR adapter.

Since its introduction in 2000, StudioHub+ has become the favorite wiring method for thousands of radio studios. The popularity of StudioHub+ format has inspired many broadcast equipment manufacturers to include RJ45 connectors on their products, replacing or supplementing other connector types. When connecting those products to RAVE!, you will not even need an adapter, just a shielded CAT-5 cable.

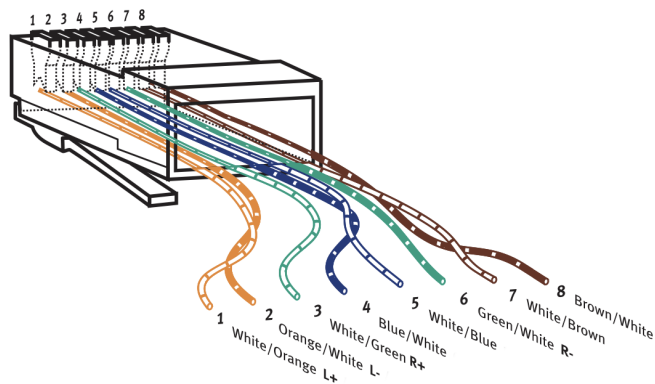

StudioHub+ pinout.

Some engineers like to make their own cables. Here's the pinout for those overachievers. For everyone else, off-the-shelf shielded CAT-5 cables work great. Click click, you'll get spoiled quick. Who knows? You might even forget how to solder XLR connectors.

In fact, there's a special StudioHub package that includes all the adapters and cables you'll need to hook up your console quickly. Ask your favorite reseller about the STUDIOHUB RAVE kit. Spend less time wiring and more time playing working with your new console!

RAVE! is engineered for professional broadcast. All of the inputs and outputs are fully balanced. Line inputs and outputs operate at a nominal +4dBu. There is a special feature on channels 5 and 6 that allows for unbalanced sources. You'll use a StudioHub to RCA adapter and flip a switch to boost the lower -10dBV level of unbalanced consumer-type (IHF) source equipment.

The StudioHub wiring standard requires the use of shielded CAT-5 (or better) cables. Most common network cables are unshielded. If in doubt, inspect the male connectors on the cable ends. Shielded connectors will have conductive surfaces that mate to the shielded RJ45 jack. Do **not** attempt to wire the console with unshielded cables. At best you will have poor noise performance, and at worst, you may defeat some of the circuitry that protects your equipment from ESD damage.

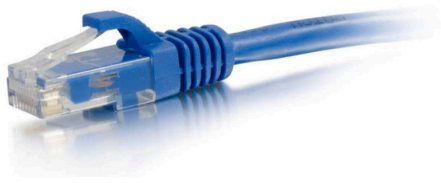

✗ *Unshielded CAT-5e cable.*

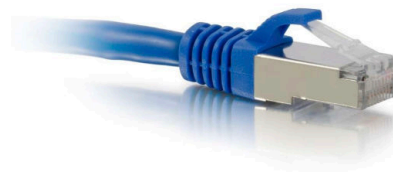

✓ *Shielded CAT-5e cable.*

Control Wiring

One of the distinguishing characteristics of radio consoles vs other types of audio mixers is the inclusion of control logic. An example is the muting of monitor speakers when microphones are turned on to prevent feedback.

RAVE! contains a number of useful logic functions that can greatly enhance the speed and quality of your live radio show. Your guests will be able to remote control their microphones for example. Another example is that line sources can receive a start pulse when their fader channel is activated.

Logic is on RJ45 connectors. Care should be exercised **not** to plug audio into logic ports and vice versa. We will cover the functions and the pinouts of the logic ports a bit later. For now, we will only mention that you will need shielded CAT-5 cables for **all** logic and audio connections. Do not attempt to wire the console with unshielded (computer network cable is often unshielded) cables.

Cable Management

We suggest you label your cables during the installation process. You'll be glad you did if you ever need to unplug and replug things. Installing a few cable grommets just behind the rear of the console will allow you to route the cables under your table for a clean appearance. Or if you're one of those folks who can turn a server room into a work of cable art, go ahead and leave it all topside where everyone can admire your talent. And send us a photo so we can admire it too!

Microphone/Line Inputs (Channels 01-04)

Each of channels 01, 02, 03 and 04 can be either microphone or stereo line source. A recessed switch for each input allows you to choose between the XLR and the RJ45 input.

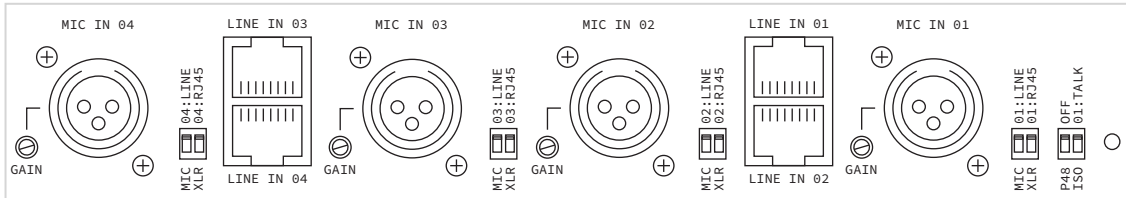

Inputs for fader channels 01-04.

If you choose the XLR, connect a microphone to the XLR connector using a quality shielded microphone cable. The XLR feeds a high-performance microphone preamplifier. A recessed screwdriver adjustable control next to each XLR connector is for preamp gain adjustment for that input.

If you choose the RJ45, connect a stereo line-level source to the RJ45 connector. These inputs expect a +4dBu balanced audio source. The gain adjustment control will not affect line levels.

CONNECTOR	PIN	SIGNAL	LEVEL
Mic In 01/02/03/04 XLR	1	Microphone Shield	-50dBu nominal, Adjustable
Mic In 01/02/03/04 XLR	2	Microphone Hot	-50dBu nominal, Adjustable
Mic In 01/02/03/04 XLR	3	Microphone Cold	-50dBu nominal, Adjustable
Line In 01/02/03/04 RJ45	1	Left Line Hot	+4dBu, Fixed
Line In 01/02/03/04 RJ45	2	Left Line Cold	+4dBu, Fixed
Line In 01/02/03/04 RJ45	3	Right Line Hot	+4dBu, Fixed
Line In 01/02/03/04 RJ45	6	Right Line Cold	+4dBu, Fixed

Connector pinouts for fader channels 01-04.

Another recessed switch on each of the inputs allows you to choose whether the channel will operate with mic logic or line logic. Mic logic mutes the monitors and provides remote mic control on the logic connector. Line logic provides start pulses and remote ON on the logic connector.

Most often, if you have selected the XLR, you will also select mic logic. Likewise, if you select RJ45, you will usually choose line logic. But if you are using an external preamp and processor, you may use the RJ45 line input and still want mic logic for that channel.

Channel 01 has a few added features. By default, channel 01 is the source for talkback audio (Talk to Mix-Minus, Talk to Studio). If your DJ is also the board operator, this is exactly what you want. There is a recessed switch labelled ISO/01:TALK. Put this switch in the up position.

However, in rare circumstances, the board operator may not be part of the show. S/he will still want to be able to talk back, but you won't want to use up an entire fader channel for that. Flip that switch to the down (ISO) position and it will allow you to use the RJ45 as the source for fader channel 01. Connect a talkback microphone to the XLR connector for the board operator as a talkback source. This audio will only be used for talkback.

RAVE! has a built-in +48VDC phantom power supply for condenser microphones. If any of your microphones require phantom power, flip the recessed P48 switch to the down position. The red LED on the rear panel will illuminate. Phantom voltage will be applied to all of the XLR connectors. This will not harm properly-wired dynamic microphones. If all of your microphones are dynamic, leave the P48 switch in the up position.

Microphone Calibration

RAVE! Microphone preamps are factory set for -50dBu nominal level. If you wish to change the preamp gain, place the fader at the nominal (bold line) mark and adjust the microphone preamp gain until your nominal mic level produces +4dBu nominal output level on either the Program or Audition output. We recommend the use of a signal generator and analyzer for this adjustment. But if you must adjust without such equipment, you will want to aim for 0VU on the meter which corresponds to +4dBu at the outputs.

Line Inputs (Channels 05-08)

As mentioned in the previous section, fader channels 01, 02, 03 and 04 are switch selectable to be either XLR or RJ45 sources. If the RJ45 has been chosen, feed stereo +4dBu audio into this input.

Fader channels 05 and 06 have RJ45 connectors for stereo line-level sources. These two channels each have a switch that will allow you to accommodate an IHF consumer type unbalanced source. For professional +4dBu sources, place the IHF/PRO switch in the up position. For consumer -10dBV (IHF) sources, flip the switch to the down position. If you have an unbalanced audio source, use a StudioHub to RCA adapter and keep the cable length as short as possible.

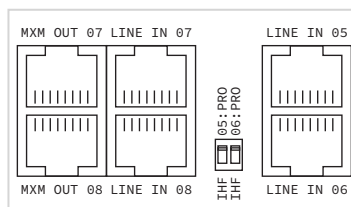

Inputs for fader channels 05-08.

Fader channels 07 and 08 also have RJ45 connectors for stereo line level sources. Feed stereo +4dBu audio into these inputs. You can use fader channels 07 and 08 for any line-level source. However, if you have any sources that require an associated mix-minus output, these are the two channels that must be used.

CONNECTOR	PIN	SIGNAL	LEVEL
Line In 05/06 RJ45	1	Left Line Hot	+4dBu or -10dBV, Switchable
Line In 05/06 RJ45	2	Left Line Cold	+4dBu or -10dBV, Switchable
Line In 05/06 RJ45	3	Right Line Hot	+4dBu or -10dBV, Switchable
Line In 05/06 RJ45	6	Right Line Cold	+4dBu or -10dBV, Switchable
Line In 07/08 RJ45	1	Left Line Hot	+4dBu, Fixed
Line In 07/08 RJ45	2	Left Line Cold	+4dBu, Fixed
Line In 07/08 RJ45	3	Right Line Hot	+4dBu, Fixed
Line In 07/08 RJ45	6	Right Line Cold	+4dBu, Fixed

Connector pinouts for fader channels 05-08.

External Line Input

There is one additional line input connection: the External source for the monitors. This may be audio from a radio tuner or from some other source you may want to be able to monitor, but is not going to be a source for your show. Feed stereo +4dBu into this input.

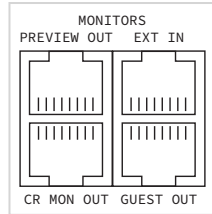

External Input for Monitors.

CONNECTOR	PIN	SIGNAL	LEVEL
Ext In RJ45	1	Left Line Hot	+4dBu, Fixed
Ext In RJ45	2	Left Line Cold	+4dBu, Fixed
Ext In RJ45	3	Right Line Hot	+4dBu, Fixed
Ext In RJ45	6	Right Line Cold	+4dBu, Fixed

Connector pinouts for External Monitor Input.

Program and Audition Outputs

All line outputs on RAVE! are fully balanced, +4dBu nominal. Exercise care when connecting outputs so as not to inadvertently short either the hot or cold lines to ground. If you need to drive a piece of unbalanced equipment, use the hot line for signal, use the shield (RJ45 shield) for both shield and signal ground. Do **not** connect the cold line.

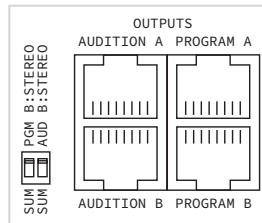

Program and Audition Output Connectors.

The primary outputs are Program A and Audition A. The secondary outputs are Program B and Audition B. Program A and Audition A will always be stereo outputs. Recessed switches allow you to choose whether Program B and Audition B are also stereo or summed mono.

On Program B and Audition B, if you have selected summed mono, this will add Left and Right together and put the resulting mono signal on both the left and right outputs. RAVE! has a built-in distribution amplifier providing isolation between Program A and B and also between Audition A and B.

CONNECTOR	PIN	SIGNAL	LEVEL
Program A	1	Program Left Line Output Hot	+4dBu, Fixed
Program A	2	Program Left Line Output Cold	+4dBu, Fixed
Program A	3	Program Right Line Output Hot	+4dBu, Fixed
Program A	6	Program Right Line Output Cold	+4dBu, Fixed
Program B	1	Program Left Line Output Hot	+4dBu, Fixed
Program B	2	Program Left Line Output Cold	+4dBu, Fixed
Program B	3	Program Right Line Output Hot	+4dBu, Fixed
Program B	6	Program Right Line Output Cold	+4dBu, Fixed
Audition A	1	Audition Left Line Output Hot	+4dBu, Fixed
Audition A	2	Audition Left Line Output Cold	+4dBu, Fixed
Audition A	3	Audition Right Line Output Hot	+4dBu, Fixed
Audition A	6	Audition Right Line Output Cold	+4dBu, Fixed
Audition B	1	Audition Left Line Output Hot	+4dBu, Fixed
Audition B	2	Audition Left Line Output Cold	+4dBu, Fixed
Audition B	3	Audition Right Line Output Hot	+4dBu, Fixed
Audition B	6	Audition Right Line Output Cold	+4dBu, Fixed

Connector pinouts for Program and Audition Outputs.

Mix Minus Outputs

Let's say you have a remote person on your show connected by phone or codec. You want that person to hear your show so they can interact with you. You might think to feed them Program since they are part of the show. But as soon as you turn them on, they will hear the show (good) and also themselves (not good). In most cases, they will hear themselves echoed back which makes participation nearly impossible.

This is why you would want a mix-minus (N-1). In the above example, if we fed them Program minus themselves, they could fully participate without echo. RAVE! makes this super easy. Plug the output from your device into LINE IN 07. Plug the MXM OUT 07 into the input of the same device. Need another? Plug it into LINE IN 08 and use the MXM OUT 08 to feed it.

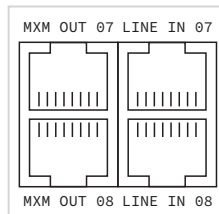

Mix-minus Output Connectors.

The Mix-Minus outputs, like all RAVE! line outputs, are fully balanced, +4dBu nominal level. The Mix-Minus outputs are monaural but show up on the left and right output pins in case you need to feed a stereo device.

A computer running Skype or Zoom makes an excellent two-way conferencing device. Angry Audio makes the USB Analog Audio Gizmo for interfacing your computer to RAVE! Connect the output of the USB Gizmo to the input of either channel 07 or 08. Connect the GIZMO input to mix-minus output 07 or 08. Anyone on the other end of the Skype call or Zoom session will hear the mix perfectly, but not themselves.

A smartphone could even get into the act using the Angry Audio Bluetooth Gadget. Connect the analog outputs of the GADGET to the input of either channel 07 or 08. Connect the Gadget mix-minus input to mix-minus output 07 or 08. Your caller will hear the mix but never himself. Goodbye goodbye echo echo.

CONNECTOR	PIN	SIGNAL	LEVEL
MXM Out 07	1	Ch07 Mix Minus Output Hot	+4dBu, Fixed
MXM Out 07	2	Ch07 Mix Minus Output Cold	+4dBu, Fixed
MXM Out 07	3	Ch07 Mix Minus Output Hot	+4dBu, Fixed
MXM Out 07	6	Ch07 Mix Minus Output Cold	+4dBu, Fixed
MXM Out 08	1	Ch08 Mix Minus Output Hot	+4dBu, Fixed
MXM Out 08	2	Ch08 Mix Minus Output Cold	+4dBu, Fixed
MXM Out 08	3	Ch08 Mix Minus Output Hot	+4dBu, Fixed
MXM Out 08	6	Ch08 Mix Minus Output Cold	+4dBu, Fixed

Connector Pinouts for Mix-Minus (MXM) Outputs.

Monitor Outputs

An External Input is provided as a monitor source. This will most often be connected to a tuner or a stream decoder that is tuned to the broadcast. It allows the board operator to hear what the listeners are actually hearing. Feed +4dBu balanced audio into this input.

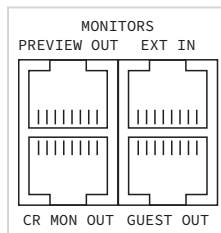

Monitor Connectors.

The Control Room Monitor Output is used to feed the amplified speaker system used by the board operator. This output will mute whenever any microphone channel is active to prevent possible feedback. This output is stereo balanced +4dBu nominal level.

RAVE! has several ways for the board operator to listen to the Preview bus. It can be routed to the Control Room Monitors or the Control Room Headphones. If desired, it can also be used to feed an external amplified speaker system. The Preview Output is a balanced +4dBu nominal level signal. It follows the Preview Volume Control and is automatically muted whenever any microphone channel is active to prevent feedback.

The Guest Output is used to feed external headphone amplifiers for your studio guests. This also is a stereo balanced +4dBu nominal level signal. In addition to the audio signal, the Guest Output also provides $\pm 15\text{VDC}$ using the StudioHub+ format. This makes it very convenient to drive one or more Angry Audio Headphone Gizmos with audio and power on a shielded CAT-5 cable.

CONNECTOR	PIN	SIGNAL	LEVEL
PREVIEW OUT	1	Preview Left Output Hot	+4dBu Nominal, Variable
PREVIEW OUT	2	Preview Left Output Cold	+4dBu Nominal, Variable
PREVIEW OUT	3	Preview Right Output Hot	+4dBu Nominal, Variable
PREVIEW OUT	6	Preview Right Output Cold	+4dBu Nominal, Variable
CR MON OUT	1	CR Monitor Left Output Hot	+4dBu Nominal, Variable
CR MON OUT	2	CR Monitor Left Output Cold	+4dBu Nominal, Variable
CR MON OUT	3	CR Monitor Right Output Hot	+4dBu Nominal, Variable
CR MON OUT	6	CR Monitor Right Output Cold	+4dBu Nominal, Variable
EXT IN	1	External Left Input Hot	+4dBu, Fixed
EXT IN	2	External Left Input Cold	+4dBu, Fixed
EXT IN	3	External Right Input Hot	+4dBu, Fixed
EXT IN	6	External Right Input Cold	+4dBu, Fixed
GUEST OUT	1	Guest Left Output Hot	+4dBu, Fixed
GUEST OUT	2	Guest Left Output Cold	+4dBu, Fixed
GUEST OUT	3	Guest Right Output Hot	+4dBu, Fixed
GUEST OUT	6	Guest Right Output Cold	+4dBu, Fixed
GUEST OUT	4	GROUND	
GUEST OUT	7	-15 VDC	
GUEST OUT	8	+15 VDC	

Monitor Connectors Pinouts.

Logic Connections

Being a true broadcast console, RAVE! is equipped with unique logic features for remote control and status indication (often called tallies in broadcasting).

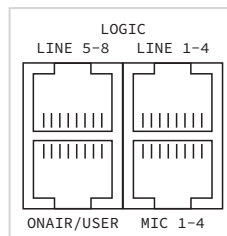

Logic Connectors.

You can remotely turn on channels configured for line sources. Short the Remote On pin to ground to turn the channel On. Note, this is not a toggle function. It only turns the channel On, not Off. The shell of the RJ45 connector is logic common. Keep that in mind when wiring logic. You will need shielded CAT5 cables to bring this ground to your device. Channels configured for line sources also have the ability to send a start pulse when the channel transitions from Off to On. The start pulse is 12V for 100ms. Again, reference the logic signal to the RJ45 connector shell which is logic common.

Channels configured for microphones can also be remote controlled. Short the Remote Switch pin to ground to toggle the channel On and Off. If the button is pressed and held while the channel is On, the channel will be muted for the

duration of the press. This mimics exactly the button on the console. A tally output illuminates an LED when the channel is On and unmuted. Use the shell of the RJ45 to provide ground for the external logic.

CONNECTOR	PIN	SIGNAL	LEVEL
MIC 1-4	1	Ch01 Remote Switch	Active low to ground
MIC 1-4	2	Ch01 On Tally	+12V Tally
MIC 1-4	3	Ch02 Remote Switch	Active low to ground
MIC 1-4	4	Ch02 On Tally	+12V Tally
MIC 1-4	5	Ch03 Remote Switch	Active low to ground
MIC 1-4	6	Ch03 On Tally	+12V Tally
MIC 1-4	7	Ch04 Remote Switch	Active low to ground
MIC 1-4	8	Ch04 On Tally	+12V Tally
MIC 1-4	0	RJ45 Shell	Logic Ground
ONAIR/USER	1	On Air Tally	+12V Tally
ONAIR/USER	2	Yellow Tally	+12V Tally
ONAIR/USER	3	Green Tally	+12V Tally
ONAIR/USER	4	No Connection	
ONAIR/USER	5	No Connection	
ONAIR/USER	6	No Connection	
ONAIR/USER	7	No Connection	
ONAIR/USER	8	RJ45 Shell	Logic Ground
ONAIR/USER	0	RJ45 Shell	Logic Ground
LINE 1-4	1	Ch01 Remote On	Active low to ground
LINE 1-4	2	Ch01 Start Pulse	+12V 100mS
LINE 1-4	3	Ch02 Remote On	Active low to ground
LINE 1-4	4	Ch02 Start Pulse	+12V 100mS
LINE 1-4	5	Ch03 Remote On	Active low to ground
LINE 1-4	6	Ch03 Start Pulse	+12V 100mS
LINE 1-4	7	Ch04 Remote On	Active low to ground
LINE 1-4	8	Ch04 Start Pulse	+12V 100mS
LINE 1-4	0	RJ45 Shell	Logic Ground
LINE 5-8	1	Ch05 Remote On	Active low to ground
LINE 5-8	2	Ch05 Start Pulse	+12V 100mS
LINE 5-8	3	Ch06 Remote On	Active low to ground
LINE 5-8	4	Ch06 Start Pulse	+12V 100mS
LINE 5-8	5	Ch07 Remote On	Active low to ground
LINE 5-8	6	Ch07 Start Pulse	+12V 100mS
LINE 5-8	7	Ch08 Remote On	Active low to ground
LINE 5-8	8	Ch08 Start Pulse	+12V 100mS
LINE 5-8	0	RJ45 Shell	Logic Ground

Connector Pinouts for logic ports.

Logic Examples

The first example is a remote On/Off/Mute button for a guest connected to channel 01. Use a momentary switch. Connect one terminal to pin 1 and the other to the shell of the RJ45. Connect pin 2 to the anode of the button LED through a 1kΩ resistor. Do not exceed 20mA of load current on the Tally line.

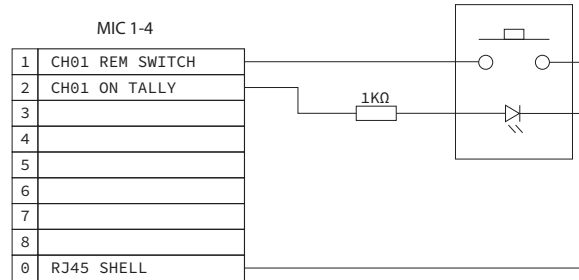

Remote Mic Control Button example.

The Angry Audio 3-segment Signal Light can be plugged into the OnAir/User connector using a CAT-5 patch cable. The red segment will illuminate when any mics are active. The yellow and green segments will follow the yellow and green user buttons. If you wish to drive an external OnAir sign, you can use the On Air Tally to energize an external relay to switch AC or DC power to your sign.

This is our second example. If you want to drive one of those big ON AIR signs when the mics are hot, no problem. You won't be able to drive that sign directly. Instead, you'll use the tally signal to drive a relay coil that switches power.

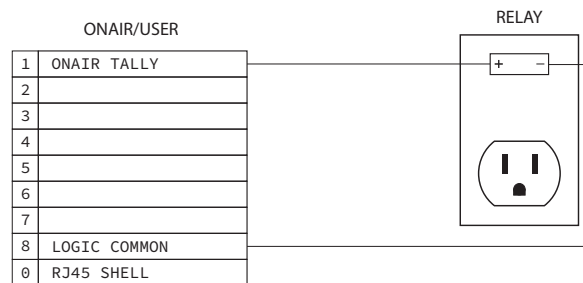

Lighting up an OnAir Sign example.

We recommend a product for this application from Digital Loggers Inc, called the IoT Relay. It is basically a relay controlled power socket. You can plug your OnAir sign into the switched outlet and drive the control pins as shown in the example drawing. It is inexpensive and works brilliantly.

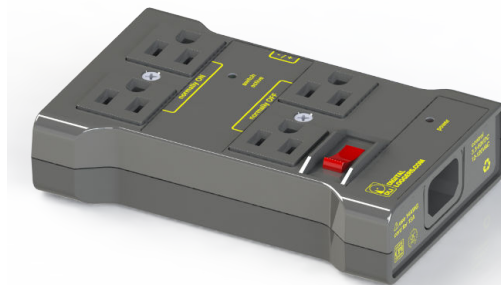

IoT Power Relay.

Fader Channels for Mic Sources

Fader channels 01 through 04 will have been configured during installation for either microphone or line functionality. This page will describe the channel strip functions when the channel has been configured for microphone.

Program and Audition switches send the output of this channel to either or both stereo outputs. Program is most often used for your main air feed. Audition may be used to create an alternate program output, a recording bus, or even a special mix to feed callers. These buttons illuminate when assigned. Press once to assign, press again to de-assign. The signal feeding the Program and Audition outputs is after the fader and after the On button.

Preview (sometimes referred to in radio as cue) is a special output used for monitoring purposes. There are various options within the monitor section for listening to preview. The preview button illuminates when assigned. Press once to assign, press again to de-assign. The signal feeding the Preview mix is before the fader and before the On button. You can preview a source even if the channel is not currently active.

The fader determines the level of this channel's source in the mix. Notice the bold line at the -10dB position. This is the nominal or "target" setting. Of course, all mixes will be a little different according to taste, but you should consider this the starting point for levels. The console gain staging is optimized at this position. If you find you need to adjust the faders a bit from the nominal, that's great. If you find that you are consistently operating faders far below or far above this mark, mention it to your engineer. It may indicate that source levels are in need of adjustment.

The On Button at the very bottom of the fader channel (again, this page describes channel strips configured for microphones) is a combination On, Off and Mute button. Tap the button to toggle the channel On and Off. The button will illuminate when the channel is On. If the channel is On, pressing and holding the On button will mute the channel for the duration of the press.

When a channel has been configured for microphone, turning On the channel strip will automatically mute the Control Room monitor speakers and illuminate the ON AIR indicator in the meter panel. It will also assert a GPO that can control an external ON AIR sign.

Note that if the channel is On and you are pressing and holding the button to mute the signal, the speakers remain muted and the ON AIR indicator remains illuminated. This is only meant to be a temporary mute (sometimes referred to in radio as cough).

Microphone channels can be remote controlled via GPIO logic. If you want, give your guests a mic with its own On/Off/Mute button that mimics the one on the channel strip.

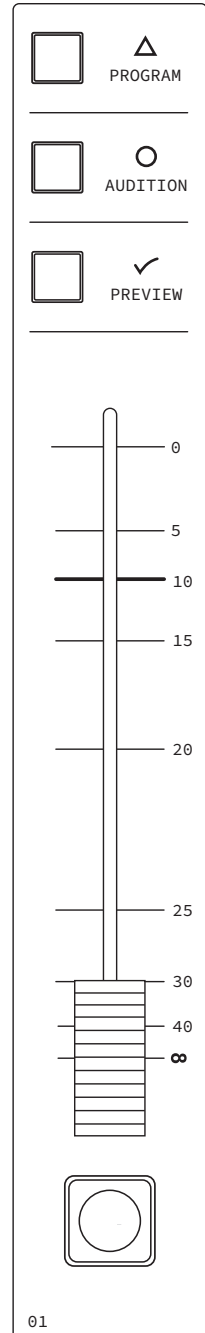

Fader Channels for Line Sources

Fader channels 05 through 08 are line sources. This page describes the function of these fader channels. It also describes any of channels 01 through 04 that have been configured for line sources.

Program and Audition switches send the output of this channel to either or both stereo outputs. Program is most often used for your main air feed. Audition may be used to create an alternate program output, a recording bus, or even a special mix to feed callers. These buttons illuminate when assigned. Press once to assign, press again to de-assign. The signal feeding the Program and Audition outputs is after the fader and after the On button.

Preview (sometimes referred to in radio as cue) is a special output used for monitoring purposes. There are various options within the monitor section for listening to preview. The preview button illuminates when assigned. Press once to assign, press again to de-assign. The signal feeding the Preview mix is before the fader and before the On button. You can preview a source even if the channel is not currently active.

The fader controls the level of this channel's source in the mix. Notice the bold line at the -10dB position. This is the nominal or "target" setting. Of course, all mixes will be a little different according to taste, but you should consider this the starting point for levels. The console gain staging is optimized at this position. If you find you need to adjust the faders a bit from the nominal, that's great. If you find that you are consistently operating faders far below or far above this mark, have a talk with your engineer. It may indicate that source levels are in need of adjustment.

The On Button at the very bottom of the fader channel (again, this page describes channels with line sources) turns the channel strip on and off. Tap the button to toggle the channel On, tap again to turn it Off. The button is illuminated with the channel is On.

Line channels can be turned on remotely via GPI, and send out a pulse via GPO whenever the channel goes On. Use this to start source equipment when you open the fader, or let the source equipment turn the channel on for you.

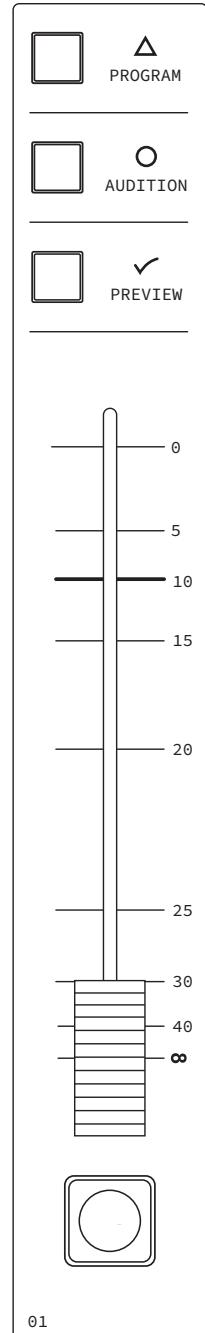

Mix-Minus Outputs and User Buttons

Your callers and guests need to hear the mix so they can participate in the show. But if you have them in the mix, they will hear themselves, delayed. The answer is to send them the mix, but subtract them from it. They need to hear everything else, not themselves. This is called a mix-minus.

Fader channels 07 and 08 can be used for any line source. But if you happen to need mix-minus outputs for your sources (phone, codec, Skype, etc.), you will want to use one or both of these channels for those sources.

The Mix-Minus 07 section allows you to choose what you send to the output feeding the source on channel 07. You can choose to send Program or Audition. You can also push to talk over that Mix-Minus output.

Likewise, the Mix-Minus 08 section gives your 08 source the ability to listen to Program or Audition. And you can push to talk over this Mix-Minus output also. It couldn't be easier.

The two buttons at the bottom of this section are User Buttons, one yellow and the other green. Each corresponds to a GPO signal that can be used to control some external device. The user buttons are toggle function. Push once to activate and again to de-activate.

If you have one of the Angry Audio 3-segment Signal Lights, these will control the yellow and green segments while the OnAir status of RAVE! will control the red segment. This is very useful in a talk environment for signaling an upcoming break or a boss sighting (time to pretend you're working, guys).

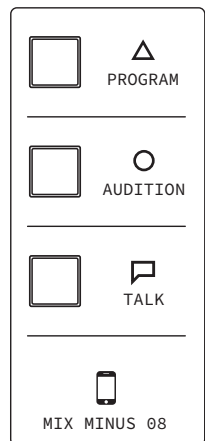
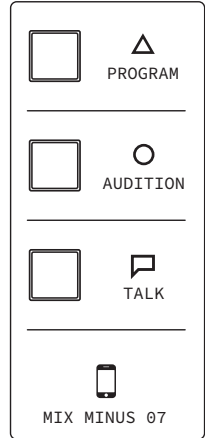

Monitors (Board Operator)

Select what you want to hear in the control room monitors by pressing one of the three buttons at the top. You can listen to the Program output, the Audition output or the External source.

The fader controls the volume of your Monitors. Start with the fader at the [∞] position, all the way toward the operator. This is the minimum volume setting. Carefully raise the fader until a comfortable listening level is achieved. Use caution. Prolonged exposure to loud sounds can permanently damage your hearing!

If you don't hear anything in the monitors, check your monitor selection. You might have selected Audition or External when you wanted to listen to Program. Also, remember that the control room monitors will mute when any microphone channel is turned on. Check the OnAir indicator in the center of the meter panel. If it's red, your monitors are muted.

Also, check to see if any channels have an illuminated Preview button and whether you have enabled the Preview To Monitors feature. If Preview To Monitors is active, when any channel preview is selected, the preview mix will override the monitor selection. The Preview volume control will affect the volume of the preview mix in the monitors. Adjust to taste. When all channel preview buttons are deselected, your monitor selection will return to normal.

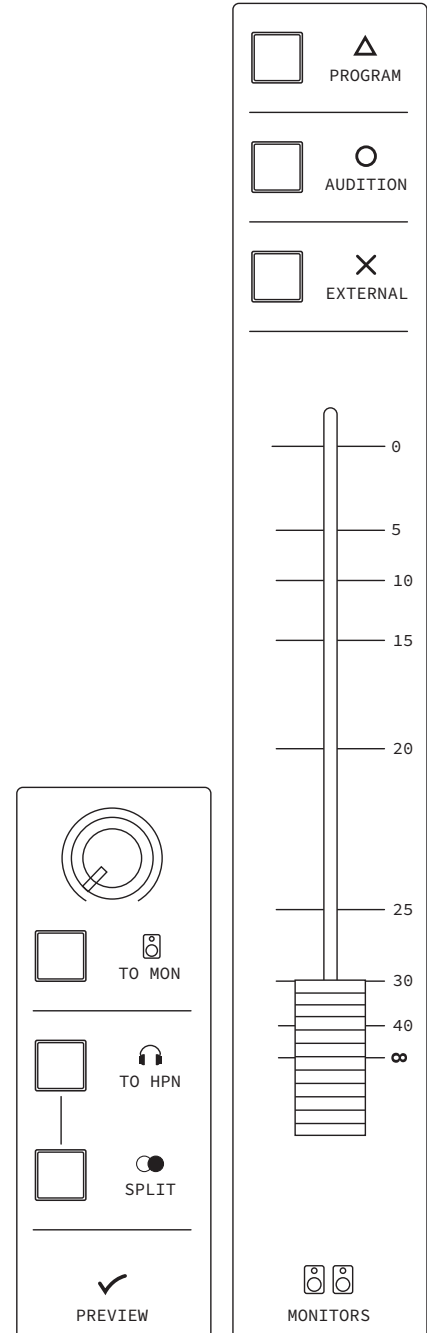

Headphones (Board Operator)

Plug your headphones into either of the two jacks on the right side of RAVE! The jacks are mutually exclusive, you cannot use both at the same time. The built-in headphone amplifier is capable of achieving very high headphone volumes. Use caution!

Select what you want to hear in the board-operator headphones by pressing one of the three buttons at the top. You can listen to the Program output, the Audition output or the External source.

The fader controls the volume of your headphones. Start with the fader at the [∞] position, all the way toward the operator. This is the minimum volume setting. Carefully raise the fader until a comfortable listening level is achieved. Be careful. Prolonged exposure to loud sounds can permanently damage your hearing!

If you have enabled the Preview To Headphone feature, then selecting preview on any channel will override the headphone selection with the preview mix. The preview volume control will have no effect on the volume of the preview mix in the headphones.

If Preview To Headphone is enabled, you can choose normal or split operation. Normal replaces your headphone selection with preview when any channel preview is active. Split sends your headphone selection to your right ear and the preview mix to your left ear.

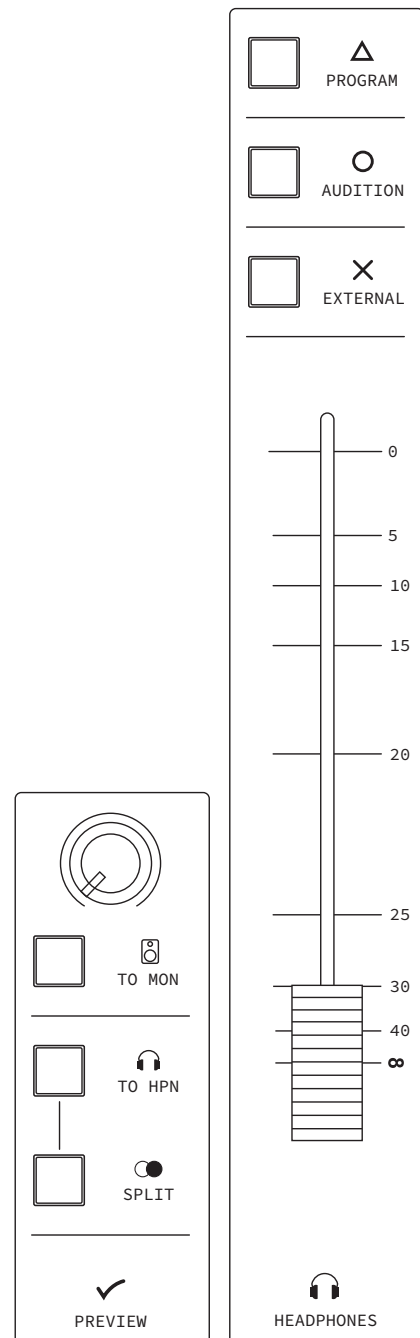

Studio Guests

Select what you want your studio guests to hear in their headphones by pressing one of the three buttons in the Studio Guest section. Choose between the Program output, the Audition output or the External source. Press the Talk button to interrupt the monitor feed and talk to your guests.

This output is intended to drive external headphone amplifiers. You do not have control of the volume on the console. The output is line level audio. Your external headphone amplifiers should be equipped with volume controls so each guest can set volume to taste.

If you use the Angry Audio Headphone Gizmo, a few shielded CAT-5 cables are all you need to provide both power and audio to up to three units.

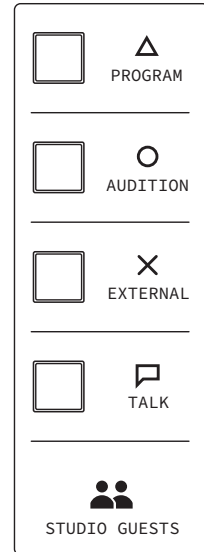

Rave! driving a chain of Headphone Gizmos.

Meters

RAVE! provides four precision LED meters for keeping track of levels. The leftmost pair are for Program Left and Right. Notice the outline around the 0 mark. This is your target mix level. If your mix is usually below this target, raise your fader(s) until you are near this point. If your mix is often above this target, you'll want to lower your faders accordingly.

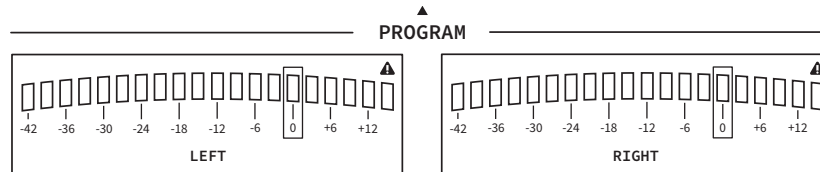

Left and right Program meters.

The target segment and all the segments to the left of it are green. The segments to the right of the target are yellow and red. Try to keep from lighting those up too often, especially the red ones. If you're finding it difficult to mix near the target without going over during loud passages, lower your levels so the loud passages are near the target and the softer passages are below it.

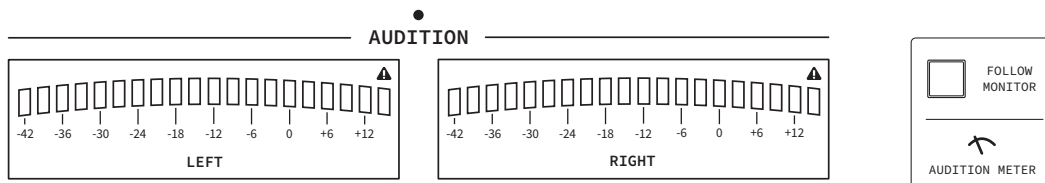

Left and right Audition meters.

The right pair are for Audition, but can also be switched to follow the selection of the headphone strip. If the Audition Meter Follow Monitor switch is active, these meters will display whatever you have feeding your headphones. If you have Preview To Headphone selected for example, the meters will display that when preview is active. This can be useful for checking the levels of a source prior to adding it to your mix.



In the center of the meter display is an ON-AIR annunciator. This will illuminate red whenever one or more microphones are active. Remember, when mics are active, the monitors are muted. So if you're not hearing anything in the monitor speakers when you expect to, a quick glance at the meter panel will tell you if you're muted.

Specifications

Part Numbers:

North America	994001
Australia	994001A
Europe	994001E
United Kingdom	994001U

Power & Environmental:

Power Input	115 VAC 50/60Hz (North America Version)
Power Input	230 VAC 50/60Hz (Australia, Europe, UK Versions)
Power Consumption	50 VA
Operating Temperature	0° to 40° C (32° to 104° F)
Storage Temperature	-20° to 45° C (-4° to 113° F)
Relative Humidity	0% to 90% non-condensing
Cooling	Venting chassis (fanless)

Performance Specifications:

Nominal Levels	Line Inputs, Line Outputs	+4 dBu	
	Mic Inputs	-50 dBu	
Maximum Levels	Line Inputs, Line Outputs	+24 dBu	
Frequency Response	Line Input to Program Output	+0 dB, -0.5 dB	20 Hz - 20 kHz
	Mic Input to Program Output	+0 dB, -0.5 dB	20 Hz - 20 kHz
SNR	Line Input to Program Output	> 88 dB	20 Hz - 20 kHz
EIN	Mic Input to Program Output	-128 dBu	20 Hz - 20 kHz , 150Ω Source
THD+N	Line Input to Program Output	< 0.002%	
	Mic Input to Program Output	< 0.007%	
Stereo Separation	Line Input to Program Output	> 80 dB	10 kHz
Bus Crosstalk	Program <> Audition	> 90 dB	10 kHz

Weight and Dimensions

Power Supply	8.25 x 6.25 x 1.75 inches	5 pounds
Power Supply (Shipping)	12 x 10 x 10 inches	6 pounds
Console	21 x 16 x 3.75 inches	19 pounds
Console (Shipping)	25 x 21 x 13 inches	22 pounds

Dimensional Drawing

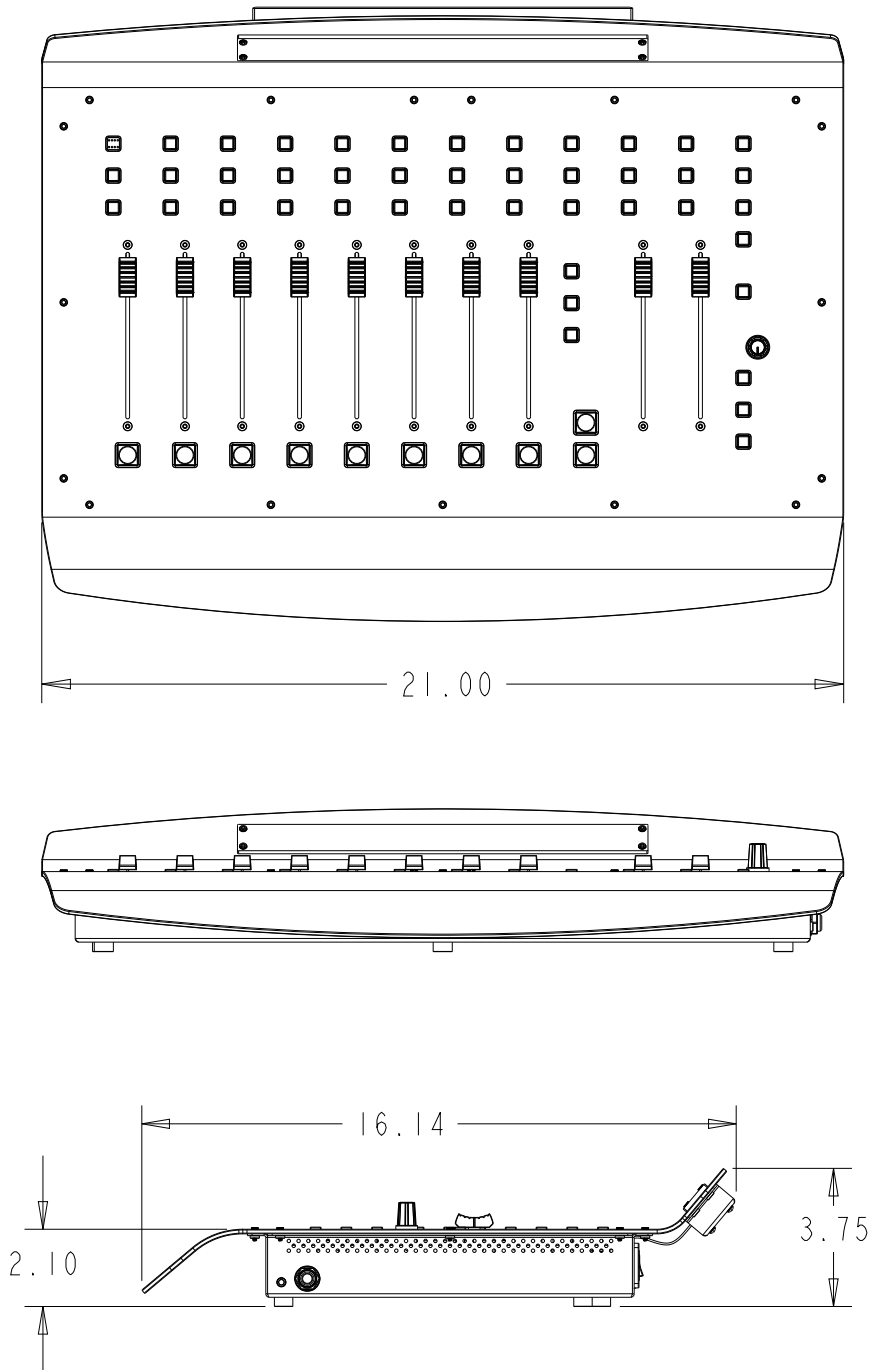

Warranty (Our Version)

The legal language below is the formal warranty. The short version: if something goes wrong, we'll fix it. Two years.

Warranty (Lawyer's Version)

This product carries a manufacturer's warranty which is subject to the following guidelines and limitations:

- A. Except as expressly excluded hereinafter, Angry Audio LLC ("Seller") warrants equipment of its own manufacture against faulty workmanship or the use of defective materials for a period of two (2) years from date of shipment to Buyer. The liability of the Seller under this Warranty is limited to replacing, repairing or issuing credit (at the Seller's discretion) for any equipment, provided that Seller is promptly notified in writing within five (5) days upon discovery of such defects by Buyer, and Seller's examination of such equipment shall disclose to its satisfaction that such defects existed at the time shipment was originally made by seller, and Buyer returns the defective equipment to Seller's place of business in Franklin, Tennessee, USA, with all packaging and transportation costs — in both directions — paid by Buyer.
- B. This Warranty is void for equipment which has been subject to abuse, improper installation, improper operation, improper or omitted maintenance, alteration, accident, negligence (in use, storage, transportation or handling), operation not in accordance with Seller's operation and service instructions, or operation outside of the environmental conditions specified by Seller.
- C. This Warranty is the only warranty made by Seller, and is in lieu of all other warranties, including merchantability and fitness for a particular purpose, whether expressed or implied, except as to title and to the expressed specifications contained in this manual. Seller's sole liability for any equipment failure or any breach of this Warranty is as set forth in subparagraph A) above; and Seller shall not be liable or responsible for any business loss or interruption, or other consequential damages of any nature whatsoever, resulting from any equipment failure or breach of this warranty.

Support

You may contact us anytime for technical or operational support. If you need to return a product for repair or refund, you will need to request a Return Authorization number. Use the form on the following page for all queries.

<https://angryaudio.com/contact>

Include the model, serial number and the name of your reseller in your communications. We watch this channel closely. You'll hear back fast.

Schematics & Technical Documentation

We usually publish schematics in our product manuals. We decided not to include them in the RAVE! manual to maintain a reasonable file size. But if you want schematics, we're happy to send them. Contact us at the link above. Include the model, serial number and the name of your reseller in your message along with your document request.