

# USER GUIDE



# ANGRY AUDIO

**PHONE**

+1 (615) 763-3033

**WEB**

answers@angryaudio.com  
www.angryaudio.com

**ADDRESS**

128 HOLIDAY CT STE 118  
Franklin TN 37067 USA



## Balancing Gadgets

P/N 991001 Stereo Balancing Gadget  
P/N 991002 Dual Stereo Balancing Gadget  
P/N 991003 Bidirectional Balancing Gadget

## Welcome to the world of Angry Audio, home of the audio gadgets.

The audio world is filled with complex, high-tech gear. Much of it bristles with seductive shapes and eye-catching lights and displays, and all of it promises to make things sound better and open up new creative possibilities.

But in order for those products to shine, you still have to get the basics right and sweat the details. Good audio isn't made by one component. It's made by getting things right every step of the way, especially the little things.

Accordingly, every audio gadget – including the Balancing Gadgets – are designed to solve common yet critical problems, and are meticulously engineered with performance and longevity in mind to deliver pristine audio for many years.

## Our promise and guarantee.

We know you'll love your Balancing Gadget, but the universe is a strange place, so it's always possible that you won't. That's why we give you 30 days to bond with your gadget. If the two of you can't get your chakras to align, we'll buy it back.

Plus, every gadget is warrantied to be free from defects in parts and workmanship for two full years after you purchase it. If a gadget fails within this time period, Angry Audio will, at its discretion, repair or replace it so long as you let us know of the failure within the warranty period and can provide proof of purchase in the form of a dated sales receipt. You can call us at +1 615-763-3033, or reach us online at [www.angryaudio.com/contact](http://www.angryaudio.com/contact).

## Making a good first impression.

When you unbox your Balancing Gadget, we really hope it makes a good first impression and you take a moment to appreciate the lengths we've gone to in order to create a "built for broadcast" product. All audio gadgets are over-engineered to provide long-term reliability and guaranteed RFI immunity.

Some of this is apparent - such as the rugged powder-coated steel chassis - but much of this goodness is invisible, like the low-noise, internal linear power supply or the direct coupled transformer-less analog circuitry. Even if you can't see it, you'll know its there by the absence of hum, buzz, hiss, or RFI.

## A word or two about safety.

Most of this falls under the category of common sense, but the company lawyers started to visibly twitch when we suggested we didn't need to go beyond a simple "Don't use your gadget in the bathtub" warning. Besides, our market research indicates that injured (or dead) customers can't be relied upon to buy more stuff, which we're told is a critical element to a successful business. Who knew?

Audio gadgets aren't chainsaws or flamethrowers, but still, they are intended to be used by qualified personnel only. To avoid electric shock, do not open the unit or attempt to perform any servicing unless you are qualified to do so.



Balancing Gadgets have internal 120VAC or 240VAC power supplies. Hazardous voltages are present whenever the unit is plugged in and may still be present on certain components even when the unit is unplugged.

The power cord is the primary disconnect device and so the outlet providing power to the gadget should be easily accessible. In other words, make sure you can back out of making bad electrical decisions by yanking the plug. Use only a properly grounded outlet for power. Do not cut the ground pin or use a ground-lifting adapter, and do not defeat the polarized plug. Do not overload outlets.

Do not expose your gadget to rain or moisture. Do not block any ventilation openings, as lack of airflow could damage the unit or create a fire hazard.

Do not run with scissors.

## Rack mounting your Balancing Gadget

The Balancing Gadget sits on four rubber feet that ensure it won't scratch the zebra wood inlays on your antique mahogany desk.

If you prefer to rack mount your gadgets, you'll need the optional Rack Mount kit which allows one or two gadgets to be installed side by side in a standard 1RU rack space.

Each Rack Mount Kit consists of a custom rack panel with cut outs for all front panel controls and displays. A blank filler panel is also provided if you are mounting only one gadget.

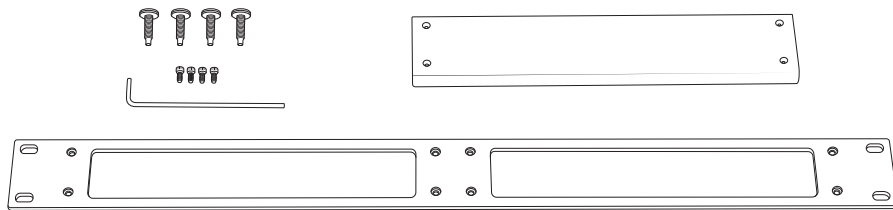

When rack mounting, remove the four rubber feet ("A") from the bottom of the gadget with a #1 Phillips screwdriver, being careful to save the screws.

Remove the four front panel 3/32" hex screws ("B"). You can rummage around your toolbox for your own hex key, or use the one we thoughtfully provide in the mounting kit.

Line up the gadget so that the holes exposed after removing the socket head screws line up with the mounting holes ("C") in the rack panel.

Attach the rack panel to the front of your gadget with the same screws you just removed. If you dropped one and it immediately rolled to an inaccessible location (as these things always do), don't panic – we've included spares in the kit.

Finally, use the provided rack screws (all four, please) to mount your gadgets.

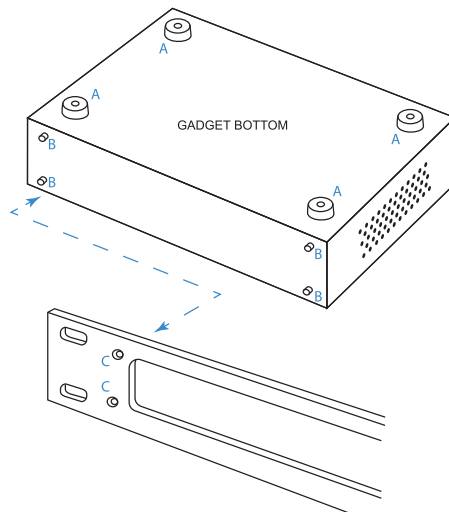

## Wall mounting your Balancing Gadget

If you prefer to secure your gadget to the inside of a rack, cabinet, or other flat surface, the optional Wall Mount kit comes in handy.

Each Wall Mount Kit includes two brackets, four No. 6 screws, and four cup washers.

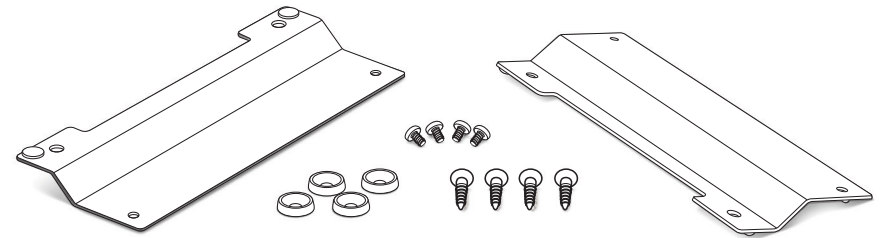

Remove the four rubber feet ("A") from the bottom of the gadget with a #1 Phillips screwdriver, being careful to save the screws.

Align the holes in the wall brackets with the holes in the bottom of the gadget, then attach the brackets using the screws removed from the rubber feet.

Use the four No. 6 screws ("B") and the four cup washers ("C") to secure the gadget to a plywood surface.

Different hardware (not supplied) will be required if you are mounting the gadget to a drywall (or other) surface.

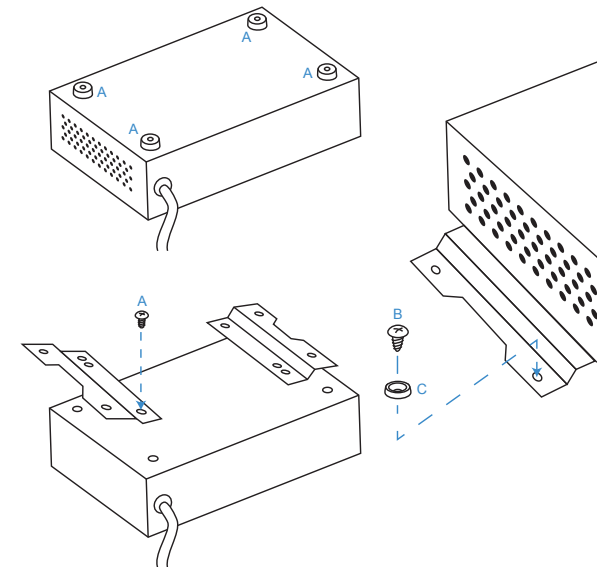

## Mounting your Balancing Gadget under a counter.

Your Balancing Gadget can be mounted under a counter, desk, or table using the optional Under Counter Mount Kit.

This kit includes two brackets, four No. 6 wood screws, and four cup washers suitable for mounting to a plywood surface. Different hardware (not supplied) may be needed if the mounting surface is a different material.

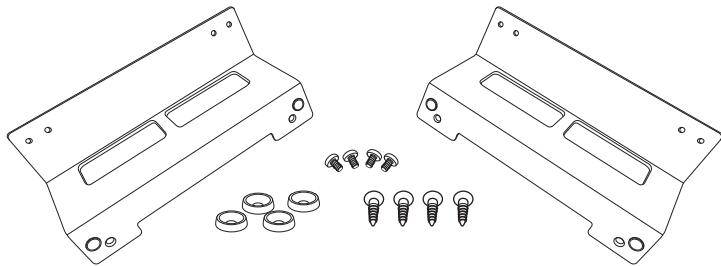

Remove the four rubber feet ("A") from the bottom of the gadget using a #1 Phillips screwdriver, being careful to save the screws.

Line up the brackets ("C") so that their mounting holes line up with holes exposed after removing the rubber feet. Orient the brackets as shown in the diagram to the right so that the deeper flat side supports the gadget and the "notched" side faces the under-mount surface.

Use the panhead screws ("B") removed from the rubber feet to secure the brackets to the gadget.

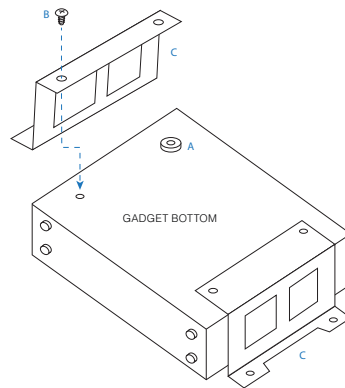

Use the four provided No. 6 screws ("D") and the four cup washers ("E") as shown in the diagram to the left to secure the gadget to the plywood underside of the counter, desk, or table.

Drilling pilot holes is recommended to reduce the risk of splitting the wood.

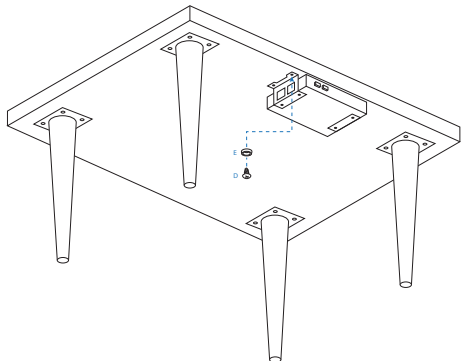

## Using your Balancing Gadget on a desktop.

If you like the idea of using the Balancing Gadget on a desktop but prefer a more permanent installation along with the convenience of having it angled up toward the user, we've got you covered with the optional Desktop Bracket Kit.

This kit includes two brackets, four No. 6 wood screws, and four cup washers suitable for mounting to a plywood surface. Different hardware (not supplied) may be needed if the mounting surface is a different material.

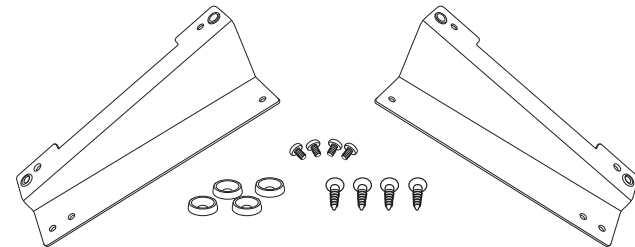

Remove the four rubber feet ("A") from the bottom of the gadget using a #1 Phillips screwdriver, being careful to save the screws.

With the bottom of the gadget facing up and the front panel facing toward you, line up bracket "C" with the holes exposed after removing the feet on the right side of the gadget. Orient the bracket as shown in the diagram to the right so that the flat side is attached to the gadget, and the "notched" side sticks up with the notch facing outwards. Use the panhead screws ("B") removed from the rubber feet to secure the brackets to the gadget.

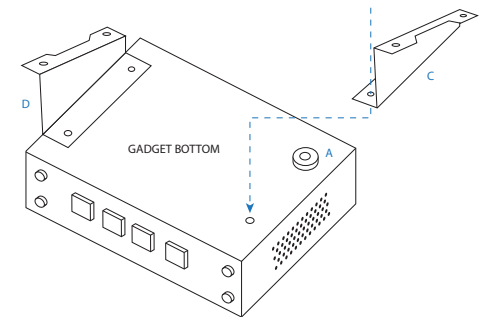

Use the four provided No. 6 screws ("E") and cup washers ("F") as shown in the diagram above to secure the gadget to a plywood surface.

Drilling pilot holes is recommended to reduce the risk of splitting the wood.

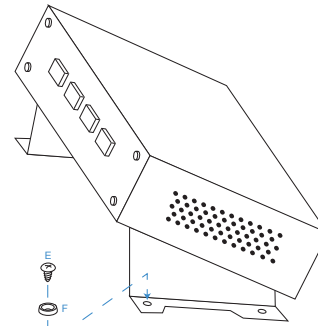

## The same, but different.

We manufacture three types of Balancing Gadgets: A stereo version, a dual stereo version, and a bi-directional version. All feature low-distortion, low-noise analog circuitry, our exclusive input stage to reduce ground loop noise, and include DC offset correction. The output amplifiers are capable of driving a +26dBu signal into long cable runs, even into low impedance 600Ω loads (+24dBm).

The Stereo Balancing Gadget converts unbalanced stereo -10dBV audio via two RCA/phono jacks to professional +4dBu fully balanced outputs on two XLR connectors, making it possible to feed professional gear with consumer audio devices.

The Dual Stereo Balancing Gadget is identical to the Stereo Balancing Gadget, but – as you may have already guessed – it offers two independent stereo unbalanced inputs to two stereo balanced outputs.

The Bidirectional Balancing Gadget converts one stereo pair from unbalanced to balanced, and another pair from balanced back to unbalanced. This makes it ideal for situations where the source and destination signals come from and go to unbalanced consumer devices, but must interface with a piece of pro audio gear in the process.



## A peak at the front panel.

This isn't exactly rocket surgery, but let's take a look at the front panel of the Stereo Balancing Gadget.

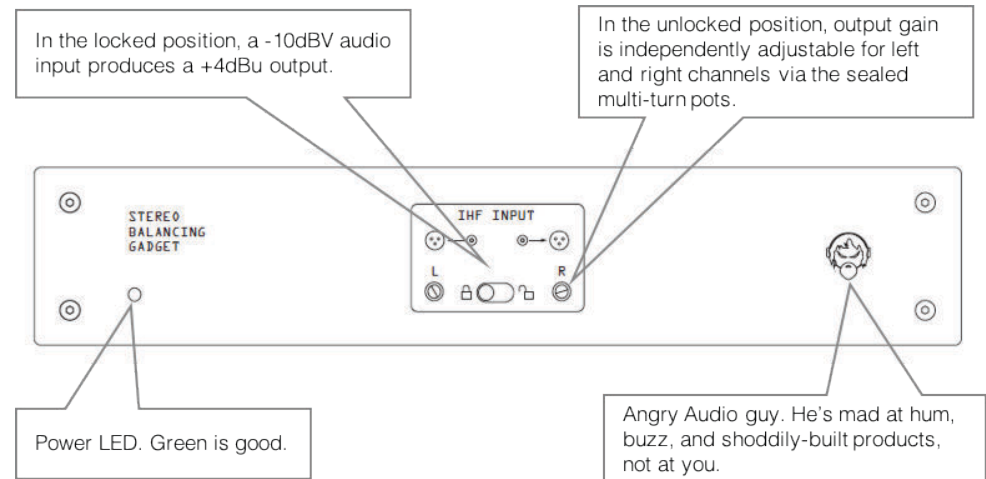

## Meanwhile, around back...

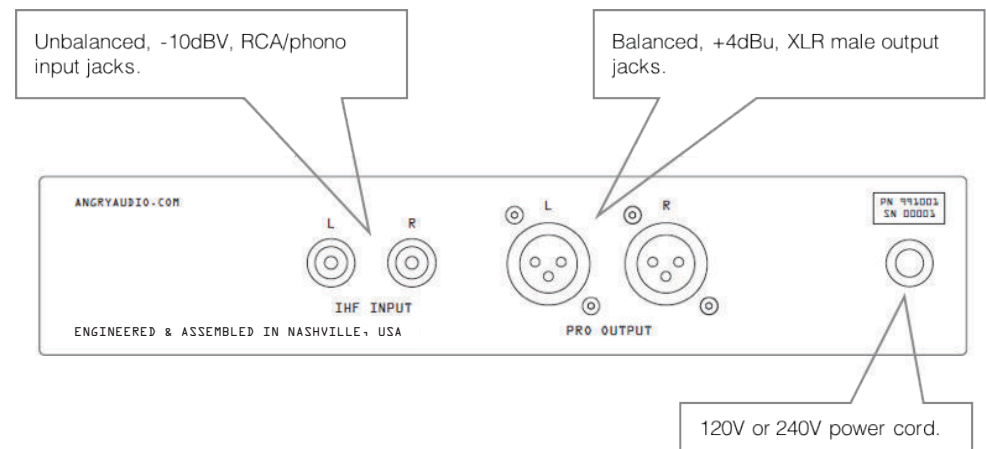

## Front Panel.

Almost identical to the Stereo Balancing Gadget, but with two inputs and outputs.

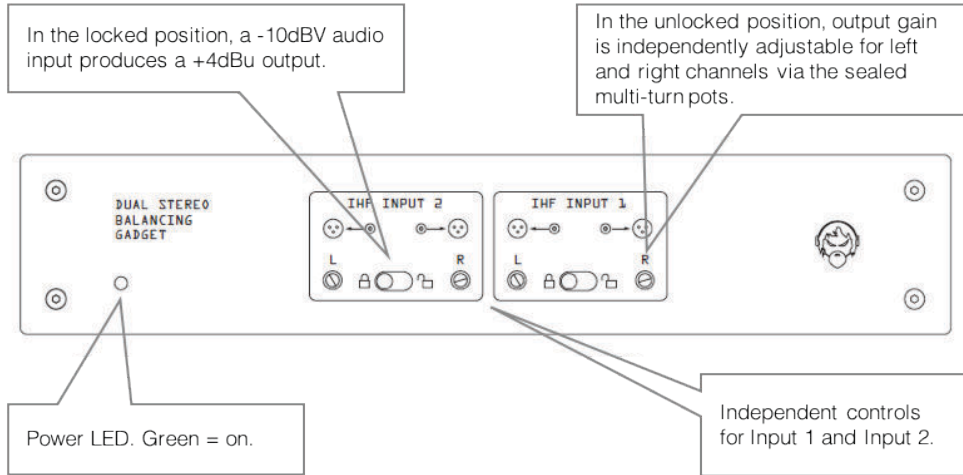

## Rear Panel.

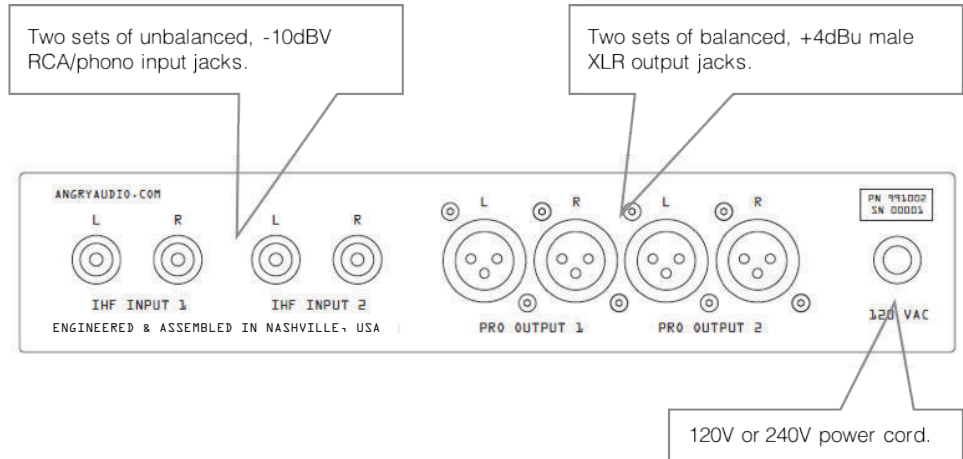

## Front Panel.

The Bidirectional Balancing Gadget is somewhat different in that it converts one stereo unbalanced pair from unbalanced to balanced, and another pair from balanced back to unbalanced.

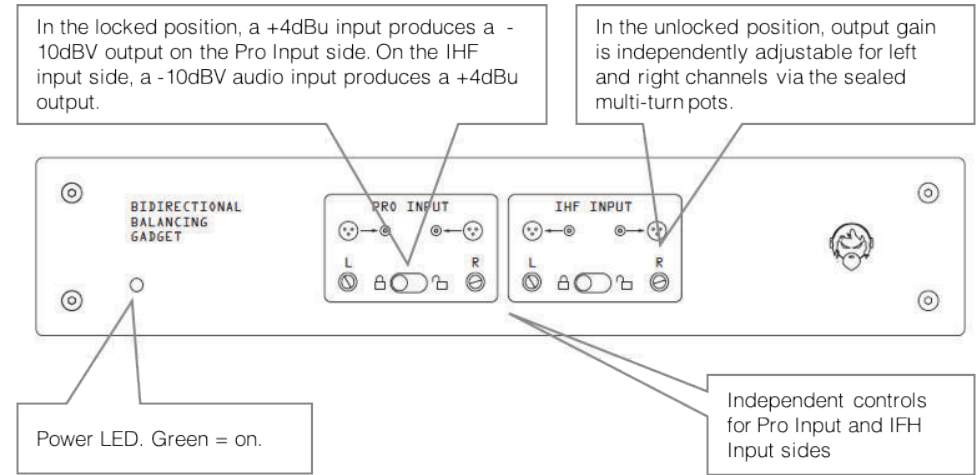

## Rear Panel.

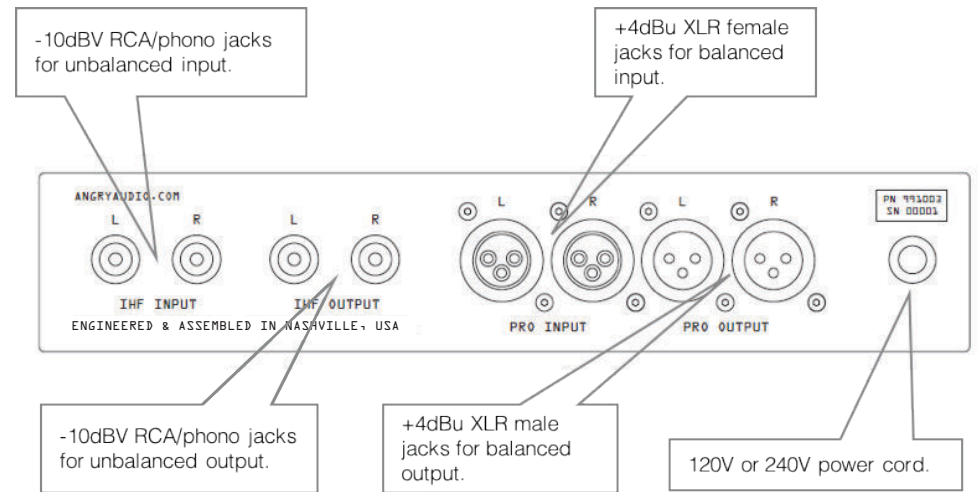

## Understanding unbalanced audio.

An unbalanced connection or cable is made up of two conductors (wires). One wire carries the audio signal, while the other serves as the shield. The most common example of this is the RCA or phono cable, where the center conductor carries the signal and the outer ring is the shield and signal return.

Unbalanced audio is most often encountered in consumer electronics equipment. It is suitable for very short interconnections, especially when the source and destination are plugged into the same power source. Unfortunately, when used to connect more distant equipment, its limitations can become quite bothersome.

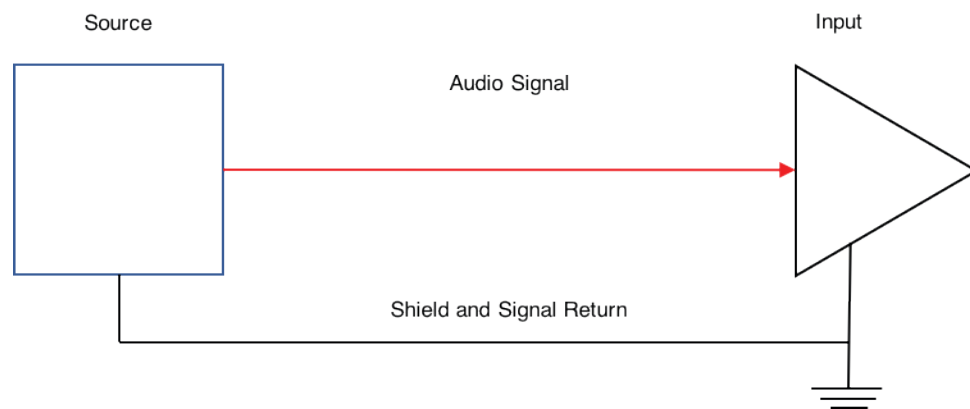

If the source equipment and the destination equipment are plugged into different power outlets, any ground differential between the outlets will appear as a common-mode voltage, present on both the signal and the shield. This is often referred to as a ground loop and may result in hum, buzz, hiss, or RF interference.

Additionally, the level of unbalanced audio is typically fairly low, with the majority of consumer (non-pro) gear having an output of  $-10\text{dBV}$ , which means even small induced noise is more apparent.

## Understanding balanced audio.

A balanced connection uses three wires, one for shield and two for signal. Most professional gear uses XLR connectors to convey balanced signals. The two signal wires are twisted together and surrounded by the shield in a balanced cable.



Balanced audio, by definition, means the two signal wires have the same impedance. A balanced audio receiving device will employ a transformer or differential amplifier input which will cancel any noise that is common to both signals and pass only the signal which is different.

Often, one signal line will carry the audio and the other will carry the same audio with opposite polarity. This is not strictly necessary, however. The same principle works if the audio return is grounded at the source. The only absolute requirement in balanced audio is that the two signal lines are impedance matched. The shield is never used as an audio return.

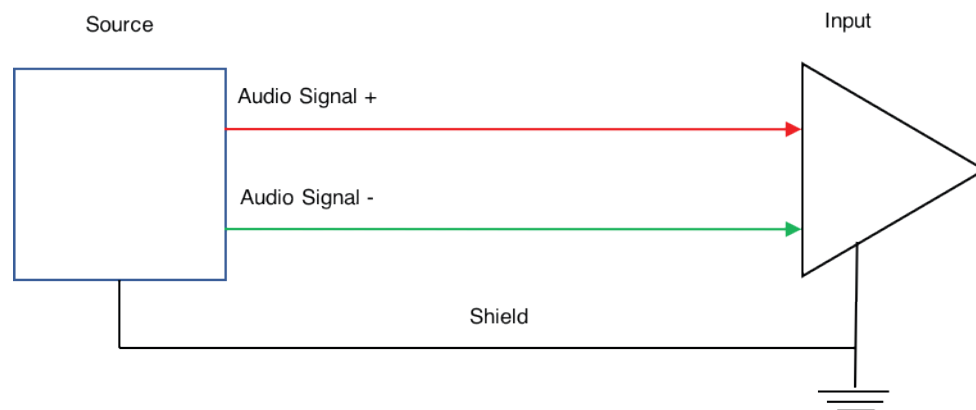

The audio levels on a balanced signal are typically  $+4\text{dBu}$  which further improves the noise suppression performance of the interconnect. These features are why balanced audio can be used for very long distances.

## Yes, that's a pun.

One of the most frequent and troubling audio issues is something called common mode noise - noise that appears on both sides of a cable - especially on unbalanced signals. This includes the ground differential, a condition more commonly referred to as the dreaded "ground loop".

When the voltage created by a ground loop hitches a ride on the audio signal, the result is typically a buzzing or humming noise, but they're also notorious for creating a handy path for Radio Frequency Interference (RFI).

Our exclusive and clever input stage rejects common mode noise, even on unbalanced sources.

## Applications

### Or, where does my gadget fit in?

Whether you're doing live sound, setting up a casual computer-based home studio to work on your own personal projects, building a dedicated recording studio, or working in the broadcast industry, there's a good chance you'll find yourself trying to make a consumer or prosumer piece of gear play nicely with pro audio equipment.

For example, the Stereo Balancing Gadget helps connect an unbalanced, consumer device such as a CD player, smart phone, or MP3 player to a balanced analog mixer.

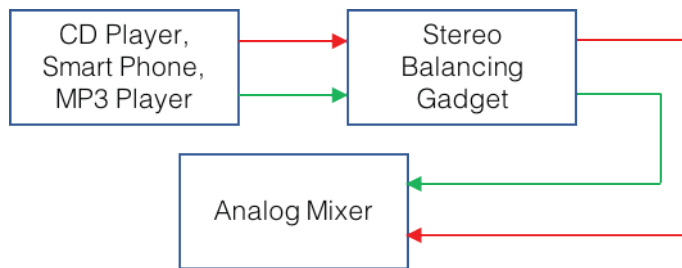

The Dual Stereo Balancing Gadget could be used to connect an MP3 player and a CD player to a small analog live sound mixing console:

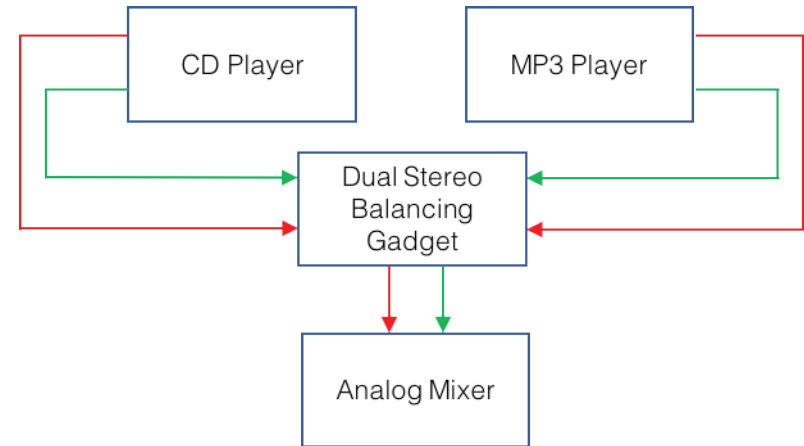

The Bidirectional Balancing Gadget is ideal for simultaneous recording and playback/monitoring with a computer sound card or external audio interface.

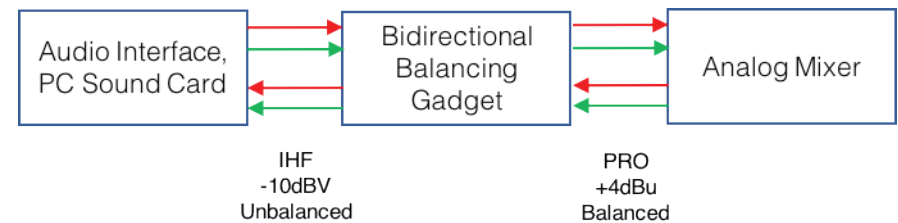

Employee productivity throughout the week:

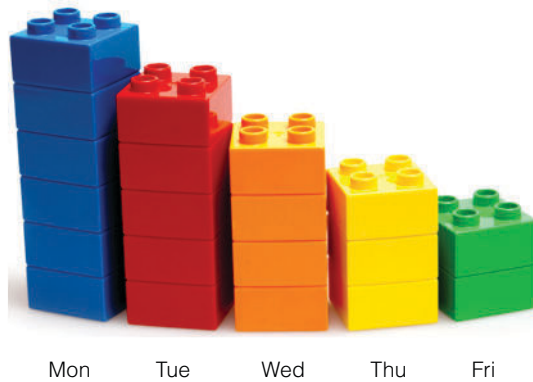

No? You meant the boring kind of diagram? Sorry.

Here's a look at the signal flow through the Stereo Balancing Gadget:

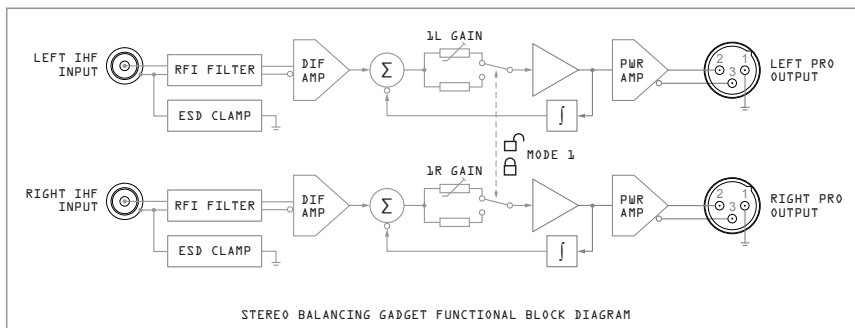

The signal flow through the Dual Stereo Balancing Gadget:

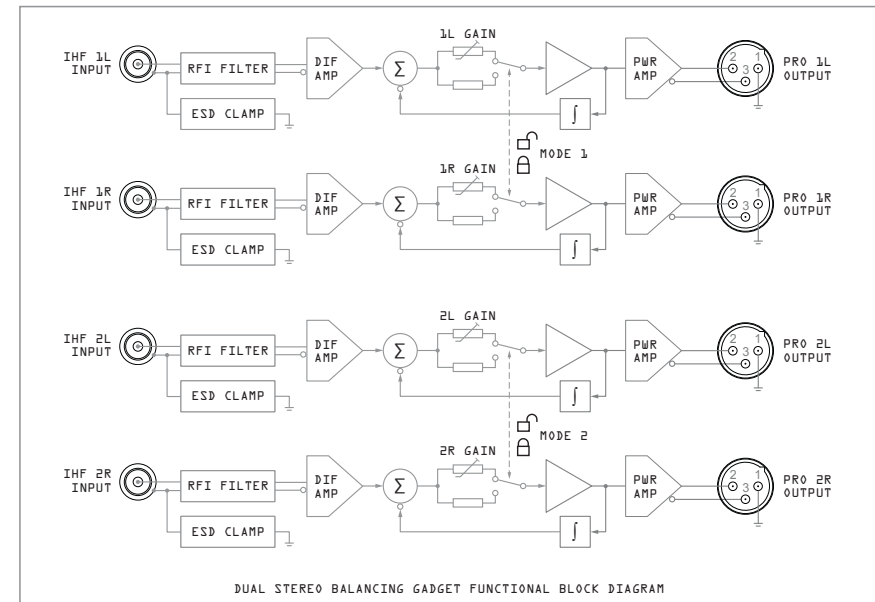

And signal flow through through the Bidirectional Stereo Balancing Gadget:

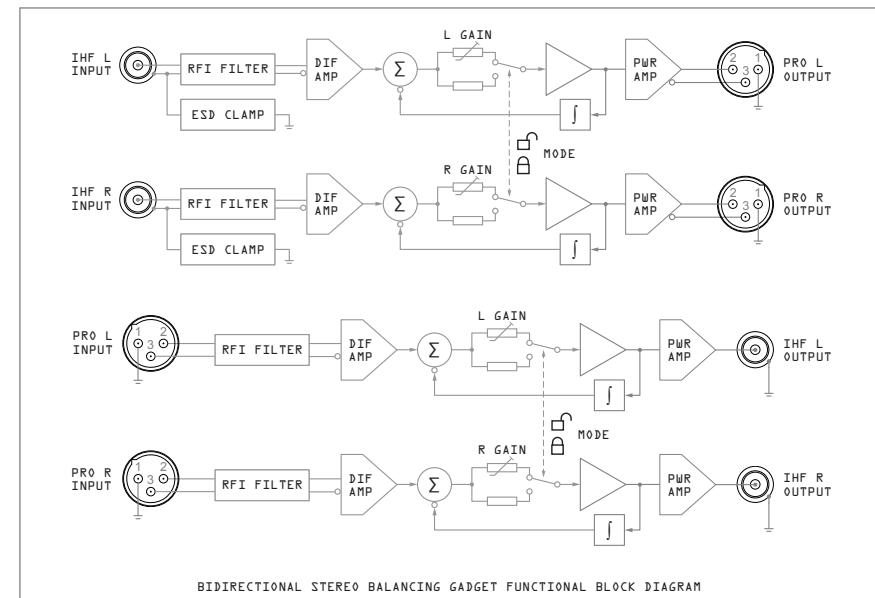

## Riveting data about your gadget.

### Part Numbers

Stereo Balancing Gadget	Part No. 991001
Dual Stereo Balancing Gadget	Part No. 991002
Bidirectional Stereo Balancing Gadget	Part No. 991003

For export versions, add suffix after part number: "E" for 230VAC Europe plug, "A" for 230VAC Australia plug, "U" for 230VAC UK plug. For example, 991001E is Stereo Balancing Gadget, 230VAC, European plug.

### Unbalanced to Balanced Conversion

Fixed Gain	+11.8dB (-10dBv in = +4dBu out)
Adjustable Gain Range	+10dB to +28dB
Frequency Response	± 0.2dB, 20Hz – 20kHz
THD+N	≤ 0.004%, 20Hz – 20kHz
Noise	≤ 90dBu (20Hz to 20kHz, fixed gain position)
Headroom	≥ 20dB
Maximum Output Level	+26dBu (+24dBm @ 600Ω load)
Input Impedance	100kΩ
Output Impedance	100Ω balanced
Crosstalk	≤ -75dB (10kHz)
CMRR	≥ 70dB (20Hz to 20kHz)

### Balanced to Unbalanced Conversion

Fixed Gain	-11.8dB (+4dBu in = -10dBv out)
Adjustable Gain Range -	-17dB to +1dB
Frequency Response	± 0.2dB (20Hz to 20kHz)
THD+N	≤ 0.004% (20Hz to 20kHz)
Noise	≤ 90dBu (20Hz to 20kHz, fixed gain position)
Headroom	≥ 20dB
Maximum Output Level	+15dBv
Input Impedance	20kΩ
Output Impedance	100Ω (pseudo-balanced)
Crosstalk	≤ -75dB (10kHz)
CMRR	≥ 70dB (20Hz to 20kHz)

Power and Environmental  
 North American Version  
 Export Versions  
 Power Consumption  
 Operating Temperature  
 Storage Temperature  
 Relative Humidity  
 Cooling

115VAC 60Hz, NEMA 5-15P power plug  
 230VAC 50/60Hz, various plugs  
 5VA  
 0° to 40° C (32° to 104° F)  
 -20° to 45° C (-4° to 113° F)  
 0% to 90% non-condensing  
 Vented chassis (fanless)

### Product Weight & Dimensions

Width x depth x height 8.5 x 6.25 x 1.70 in., 21.6 x 16 x 4.32 cm.  
 Weight 3.5 pounds, 1.6 kilograms

### Shipping Weight & Dimensions

Length x width x height 12 x 9 x 6 in., 31 x 23 x 16 cm.  
 Weight 5 pounds, 2.3 kilograms

## Compliance

### In The U.S.

In the U.S., this gadget complies with the limits for a Class A computer device as specified by FCC Rules, Part 15, Subpart J, which are designed to provide reasonable protection against such interference when this type of equipment is operated in a commercial environment.

### In Canada

In Canada, this gadget does not exceed the Class A limits for radio noise emissions set out in the Radio Interference Regulations of the Canadian Department of Communications.

### In Europe

This gadget complies with the requirements of the EEC Council Directives 93/68/EEC (CE Marking), 73/23/EEC (safety – low voltage directive), and 89/336/EEC (electromagnetic compatibility). Conformity is declared to standards EN50081-1 and EN50082-1

### A peek deep inside the Stereo Balancing Gadget.

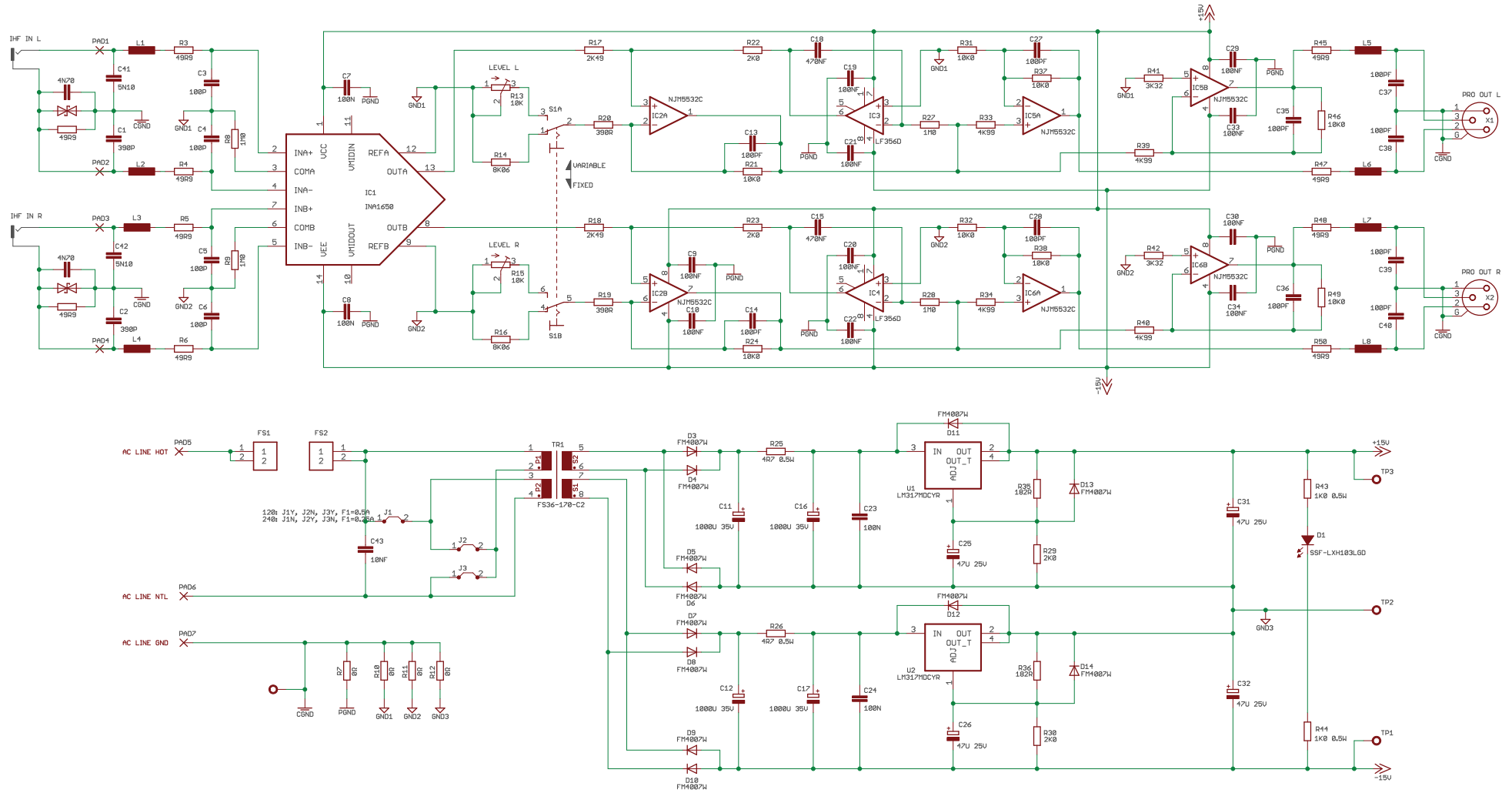

### Dual Stereo Balancing Gadget.

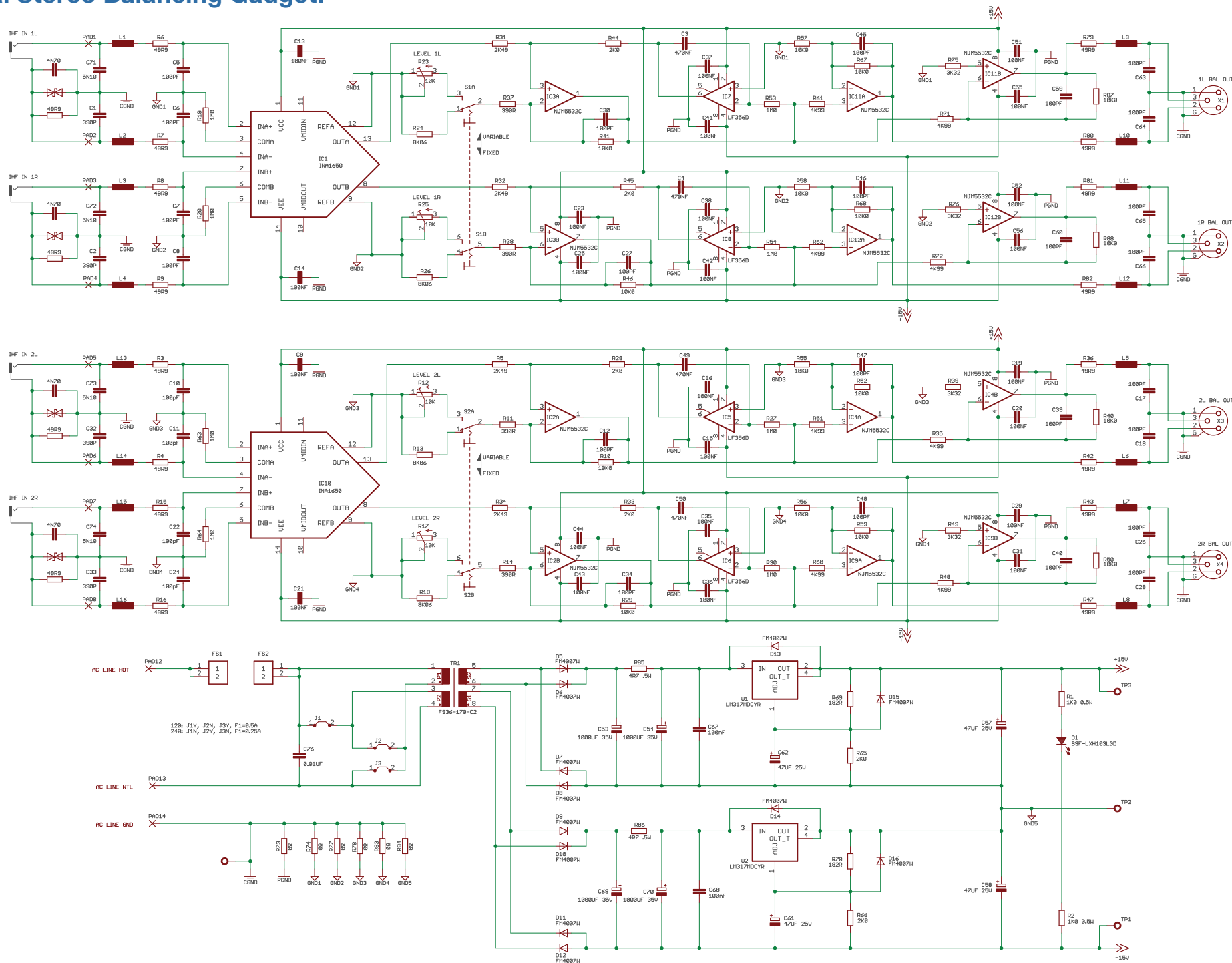

### Bidirectional Balancing Gadget.

